



ARC = 35.11'  
R = 75.00'  
S71°15'31"W  
LC = 34.79'

N34°57'40"W - 371.96'

ARC = 23.61'  
R = 15.00'  
N80°01'39"W  
LC = 21.25'

N35°07'52"W 29.49'

COMMON AREA  
0.326 ACRES

LOT #14  
0.366 ACRES

LOT #16  
0.154 ACRES

LOT #17  
0.133 ACRES

LOT #18  
0.133 ACRES

LOT #19  
0.133 ACRES

LOT #20  
0.218 ACRES

LOT #21  
0.452 ACRES

LOT #1  
0.133 ACRES

LOT #2  
0.133 ACRES

LOT #3  
0.133 ACRES

LOT #4  
0.133 ACRES

LOT #5  
0.133 ACRES

LOT #6  
0.133 ACRES

LOT #7  
0.168 ACRES

LOT #13  
0.192 ACRES

LOT #12  
0.143 ACRES

LOT #11  
0.133 ACRES

LOT #10  
0.133 ACRES

LOT #9  
0.133 ACRES

LOT #8  
0.167 ACRES

COMMON AREA  
0.258 ACRES

LOT #26  
0.134 ACRES

LOT #25  
0.169 ACRES

LOT #24  
0.156 ACRES

LOT #23  
0.327 ACRES

LOT #27  
0.133 ACRES

LOT #28  
0.133 ACRES

LOT #29  
0.133 ACRES

LOT #31  
0.334 ACRES

LOT #32  
0.288 ACRES

LOT #33  
0.127 ACRES

LOT #30  
0.166 ACRES

COMMON AREA  
0.098 ACRES

SPRINGVILLE DRIVE

FULKERSON DRIVE

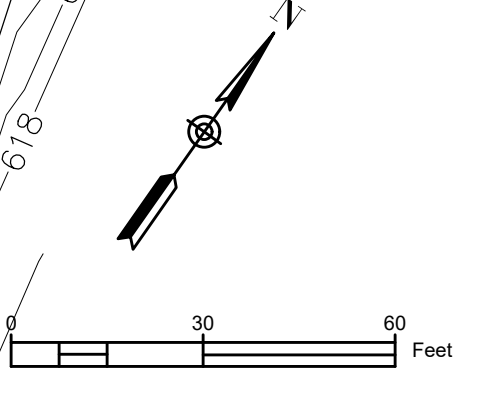

| Curve Table |        |         |             |        |
|-------------|--------|---------|-------------|--------|
| CURVE #     | ARC    | RADIUS  | BEARING     | CHORD  |
| C1          | 29.42' | 75.00'  | S69°05'12"W | 29.24' |
| C2          | 5.69'  | 75.00'  | S82°29'52"W | 5.68'  |
| C3          | 23.52' | 15.00'  | S09°57'14"W | 21.18' |
| C4          | 15.20' | 125.00' | S31°28'43"E | 15.19' |
| C5          | 47.70' | 125.00' | S17°03'48"E | 47.41' |
| C6          | 56.21' | 125.00' | S06°45'06"W | 55.74' |
| C7          | 47.70' | 125.00' | S30°34'01"W | 47.41' |
| C8          | 28.84' | 125.00' | S48°06'36"W | 28.78' |

|          |  |
|----------|--|
| By       |  |
| Date     |  |
| Revision |  |
| 7:       |  |
| 6:       |  |
| 5:       |  |
| 4:       |  |
| 3:       |  |
| 2:       |  |
| 1:       |  |

**PRIMARY PLAT**  
INFINITY HOMES  
SPRINGVILLE MANOR, PHASE 3  
CHARLESTOWN, IN

301 E. CHESTNUT STREET  
CORYDON, IN 47112  
TEL: (812) 738-4124  
FAX: (812) 738-6740

PAUL PRIMAVERA & ASSOCIATES

Date: 08/26/21  
Drafted By: JMC  
Checked By: DAS  
Directory: T:\2019\14094\PHASE  
File: 14094PP.DWG  
Job No.: 19-14094  
Drawing No.  
**C-102**